

# "The Buzz"



Eagle Wings Motorcycle Association



Chapter B SunSphere Wings  
Knoxville Tennessee  
June 2023 Newsletter

Richard & Connie Pendleton  
Tennessee District Directors  
Eagle Wings Motorcycle  
Association

Chapter B Directors  
Stanley & Patty Rinehart  
You can reach us at  
423-912-0848  
Stanleyrinehart@bellsouth.net



*SunSphere Wings  
In Knoxville, Tennessee*

*Home of the 1982 Worlds Fair  
Now Charter members of the  
Eagle Wings Motorcycle Association*



*Join us the First Tuesday each month at Shoney's Restaurant  
2405 Andersonville Hwy, Clinton, TN 37716, Exit 122 off I-75  
(Rt. 61 Museum exit) Just north of Knoxville, Ph. 865-494-7295  
Eat at 6:00 PM & our social starts promptly at 7:00 PM*

Volume 41: Number 6

Chapter B Web Site  
[www.tn-b.org](http://www.tn-b.org)

Tom & Merrilee Peck  
Newsletter Editors  
[tomkatpeck@msn.com](mailto:tomkatpeck@msn.com)

# Chapter B Staff

## Directors

Stanley & Patty Rinehart  
423-494-9818 (mobile)  
stanleyrinehart@bellsouth.net

## Web Master /Newsletter Editors

Tom & Merrilee Peck  
tomkatpeck@msn.com

## Assistant Directors

Open Position

## Treasurer

Barbara Sowder (Bill)  
423-489-4387  
bbsowder@hotmail.com

## “Couple of the Year” 2023

### **John and Doretha Thompson**

*jrt26westover@att.net*  
865-310-5428

## “Individual of the Year” 2022

Emily Lewis  
865-803-5668  
mawmawx3tce@gmail.com

## Ride Planner

Wally Maliskey  
865-617-4151  
bamawing@comcast.net

## Membership Enhancement

Merrilee Peck (Tom)  
865-256-1250  
merrileepeck@msn.com

## Chapter Store

Pat Talley  
423-494-1194  
talleylakeside@gmail.com

## Happy Trails Editor

Scott Wiens (Hedie)  
865-684-3656  
flscott66@gmail.com

## Sunshine

Emily Lewis  
865-803-5668  
mawmawx3tce@gmail.com

## Technical Advisor

Chris Harden (Julie)  
865-670-9010  
carworksofknoxville@yahoo.com

## Awards Coordinator

Patty Rinehart (Stanley)  
423-437-0810  
stanleyrinehart@bellsouth.net

## Social Coordinator

Doretha Thompson (John)  
865-603-0372  
doyle@att.net

## Stanley & Patty Rinehart Chapter B Directors



Last months meeting was a lot different than any I have been a part of by far and one of the most emotional ones I have ever been in. For all that were not there Tom and Merrilee have decided to step down as our Senior Chapter B Directors and Me and patty will be taking over as your new Chapter B Directors. Our goal will be to serve Chapter B and it's members with the same great leadership that you have been accustomed to getting from Tom and Merrilee. I wanted to let everyone know the changes that are going on and the commitment that Patty and I will be making in taking over such a great group of people that we consider to be part of our extended family and a great Chapter. As always it is an exciting time to be part of Chapter B and as our group grows so does the bond that makes this group so special. We still have a lot of good rides left on the schedule and there is also some room left if you want to add a ride in, just see Wally and he will fix you up. We are getting the Chapter shirts worked out as we have the codes and colors and the vendor that will hook us up, we also purchased some random size shirts for people to try on to check for sizing. One thing we do need is for someone to step up and take over the company store, Pat tally has did a magnificent job at this but is wanting to step down so now is your chance to step up and help, it's little things like this that makes the wheels keep going round. We look forward to seeing everyone at the meeting.

*Stanley and Patty*

Pg 2





# Tom Peck



Patty and I first came to be in Chapter B in 2013, we had just triked our Goldwing and were looking for someone to ride with. Patty came home from work one day talking about some ladies that had stopped in the store where she was working looking for donations for a fund raiser, those ladies were with a Gold Wing group called GWRRA Chapter B. I had already been looking on line for different motorcycle groups and when Patty came home with this information I looked up their website and was struck by how neat and organized it was and the friendly feel I got from looking over it so we decided to pay them a visit. The first two people we meet when we came to the meeting was Chucky Talley and Tom Peck and the rest as they say is history. As our time in Chapter B grew so did our love for the Chapter and the people in it. A few years pass by and at one of our Chapter B meetings in 2018 Patty and me were socializing before the meeting when I looked up and notice Tom was motioning me to come see him, after sitting and talking a bit he asked me if I would be interested in being the assistant Chapter Director, I couldn't say yes fast enough as I had been wanting to give back to the thing that was bringing us so much joy, little did I know and probably Tom that he was picking what might be his replacement one day. As soon as I was sworn in Tom gave me the officers handbook to read, must have took me a week to get through it. The manual would outline what was required to be a officer in GWRRA and how to conduct yourself but the book can only take you part way, the rest comes from a more senior leader and I was fortunate to be with one of the best. Tom made being a Chapter Director look easy, but it isn't , there are always things that need to be done. Tom knew how to deal with people and he knew what it took to keep a Chapter running smoothly. Tom was always working toward wanting to add more members but also working on not loosing any either, not an easy task when you consider the different personalities that you have to deal with. GWRRA would send out the ARL which was a list of new members and a list of people who's membership was about to run out and even though we had a membership enhancement officer he would go over those list and say hey we need to be contacting some of these people, it didn't matter if they had been assigned somewhere else or not, we would steal them away if we could. No matter what would come up Tom would always be looking out for what was in the best interest of the Chapter and the members in it while knowing some of the decisions would not be popular ones. I always appreciated Tom for this, no matter what it was it was what is best for Chapter B and GWRRA. Tom was a walking history book of GWRRA , I would love to sit and listen to stories of the early days of the organization and the people that would help it grow into what it was to become. There were also a lot of rules to follow and Tom knew them all, the forms to feel out for certain things or the proper steps to take on getting things done, there was always that attention to detail and to make sure it was done right. For the ten years that Patty and I have been in Chapter B the one constant has been Tom Peck. There were so many things I wanted to say to this good man in front of all the Chapter after it was announced but emotion would not let me get the words out. Everyone in Chapter B owe's this man a debt of gratitude for the outstanding job he has done, when so many Chapters lost members or folded Chapter B grew, Tom made Chapter B what it is today. I could not have been more fortunate to have him as my mentor on this journey to being the next Chapter B director but most importantly like all of you I get to call him friend. Thank you Tom and Merrilee Peck for all you have done for me and everyone in Chapter B.





# Chapter TN-B



Tom and Merrilee Peck  
Thank You

# Happy Trails



## Successfully Navigating Switchbacks: Part 1 – Downhill Switchbacks

In last month's newsletter I wrote part one of a two-part series on navigating switchbacks on a two-wheeler. That article was about navigating a switchback while heading downhill. In this article we will discuss navigating switchbacks while riding uphill.

Right out of the gate it is important to know that the level of difficulty is higher when going around a switchback while heading uphill. This is due to a couple of factors. First, you don't have the full visibility that you typically have when heading downhill and secondly, when going uphill the motorcycle is under power versus braking when going downhill. I have never had an anxious moment navigating a switchback while heading downhill but I have had a couple going uphill. If you two-wheel riders are honest you will probably agree.

With that as a background let's cover some tips for successfully navigating a switchback while travelling uphill:

- 1. Get to the Correct Speed BEFORE Entering the Switchback** – The right speed is always a matter of the rider's judgment, and it will largely depend upon the tightness of the switchback. However, it is ALWAYS better to go in too slow than too fast. Slowing down on an uphill switchback means you will be on the brake for a second or two and then must immediately apply the throttle. This can be done but it is more of a challenge and is commonly the cause of riders falling over.
- 2. Get Your Bike into the Right Gear BEFORE Entering the Switchback** – I can't emphasize this enough. You are about to navigate a tight turn while heading uphill so you MUST be in the correct gear so the bike will have the torque to pull you through the entire turn. For most of the tight switchbacks that we ride on the smaller roads here in East Tennessee that gear should be 1<sup>st</sup> or 2<sup>nd</sup>. The danger of being in too high a gear will be obvious to most all of you. When you need to apply the throttle to keep control through the turn and your bike is in too high a gear, the engine will bog down, and you won't have the torque you need. That means you are in danger of losing control of the bike.
- 3. Turn Your Head in the Direction of the Curve** – These last three points I mentioned in the first article but are still important to note. Don't forget to turn your head and eyes and focus on the curve and not what is directly in front of the bike.
- 4. Handlebar Steer** – Because a switchback is such a sharp turn you will be going slow and therefore must handlebar steer.
- 5. Remember Outside-Inside-Outside** – As I mentioned last week, use the technique of starting on the outside (right) part of your lane, move to the inside (left) of your lane as you go through the switchback (close to the center line) and then back to the outside as you come out of the switchback. It will take some of the sharp angle out of the curve which in turn should help you navigate it more effectively.

Hope this helps. In upcoming articles I am planning on writing some articles specifically for the trike riders in our midst. As part of my research for these I will be talking to a few in addition to my other research as, of course, I am not a trike rider (yet).

Happy trails everyone!

Scott





# Roan Mt. Steak Out

Well As another Roan Mt. Steak out goes down in the books, I have to say even though the crowds of old were not there we still had a great time. Patty and I took the camper as we planned on camping in the campground right next to where the event was held. We arrived on Thursday and hopped out of the truck with shorts and t-shirts expecting to feel nice temperatures but



was meet with cold air and breezy, it didn't take long to have on sweats and a hoodie to stay warm. We had a great spot and it is only a short walk to the event and we were lucky to have Roy and Joyce staying in the campsite right behind us, nothing beats camping with friends. It didn't take long for Roy to get a good camp fire burning to knock the chill off. Friday brought some sunshine and warmer temps and set the start of what turned out to be a fun day that ended with us at our first Bean supper, we had always heard of them but had never had the chance to make one and this one did not disappoint. There were not a lot of people there but the quality of the people that showed up made for a fun evening. We had several

Chapter B people in attendance as Tom and Merrilee and Dave and Betty had made the ride in along with Rick and Denise who drove in and they all had rented cabins to stay in. The beans and cornbread were really good, they also did 50/50 tickets and the winning number belonged to Patty. Saturday had us starting the day with over cast skies and the chance of rain in the air. We were fortunate to have some more Chapter B



people show up for the Steak Out with Kyle and Bobbie and Emily all driving in so there was a good showing of Chapter B people in the house. We had a corn hole competition before the steaks were to be served and by luck of the draw Patty and I won the cornhole event. The steaks that were served were great, along with a bake potato, salad, rolls and a desert and by the end of it I was stuffed. At the end of the event there were more 50/50 ticket drawings which saw Tom win one and Richard win the



other one, there was also a drawing for a real nice riding jacket which was won by Patty so all in all Chapter B won everything that went on plus we had the most people form any Chapter to show up. Not bad for a nice weekend of food and fellowship. This was the 40<sup>th</sup> year for Chapter C holding this event and even though the crowd was small the comraderies and fellowship was large. We were told when it first started that Chapter B had the largest showing and 40 years later, we still had the largest Chapter showing up. I know dwindling participation in a lot of Chapters today really hurts events like this but I hope these guys keep this going and if they do, Chapter B will be there. As we puled out of the campground headed home we made it to the Broadway exit on 640 when



we had a trailer tire blow out, as soon as we got stopped we had one of those T-Dot trucks pull over to help, this guy had our tire changed and we were rolling again in 18 minutes flat, wow what a job these guys do and were very thankful he showed up, this just capped what we felt like had been a blessed weekend.





# Technical Coordinator: Chris Harden



Brake light switches on a Goldwing there are several switches sometime they get corroded and quit working the switches are located underneath the controls on the right side touching the brake lever when pulling in the brake lever you should hear a audible click but it doesn't mean the switch is actually working if you are having brake light issues or cruise control problems this is what I would look at first sometimes it's as simple as working the switch back and forth other time you have to replace switch.

Clutch switch there is actually two switches one for starting one to disengage cruise control the same applies to them about cleaning and replacements if necessary.

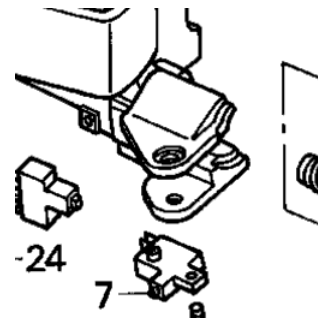
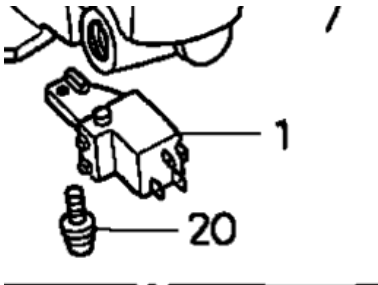

Chris



# Niagra Falls



We been on the run ever since we left home. 3 glorious days in Niagara Falls, the weather has been sòòòòò perfect! Lots to see and do in the falls area. Saturday dinner in the tower, up and headed east into New York lunch here in Utica as we make our way towards Lake George. Temps just hit 90 it was a perfect time to stop a Burger King for a quick bite to eat, cool down, then hit the road.

Should reach Americade early this evening.



Our riding group is now a finely tuned machine as we ride in perfect formation. Got the hand it to everyone for their group on this trip, they have honed their riding in this group, tight formations and staggered style. The weather has been perfect the whole time we been on the road, tempers have been calm for a group of 14. Look forward to a good rally and trip back home to. Tennessee. See you all at the picnic.

Tom & Merrilee Peck





Send us your For Sale items or Wanted to Buy items. Pictures and a full description with price always helps.

2004 Goldwing 1800, 72K miles, all services and maintenance are up to date. New windshield and other new parts. This belonged to the former CD of Chapter F in Morristown and has been well maintained.

Custom pin striping and lights. It can be seen at Car Works of Knoxville on Oak Ridge Highway. Chris has done the maintenance and it is ride ready. Price drop, asking 6450.00 OBO. Contact Richard James at 865-441-5770.



# Let's Get signed Up



For those who have signed up and Joined our new Association you will be given a member number.. Several have joined before the cut off date and will be considered a Charter member. Please forward your number to Stanley so we can build our member roster. Our new association will take awhile as it grows and will eventually provide individual Chapters this information . This information is also needed so we can make up new membership drawing tags for our member drawing each month.

It may take several weeks to get your new membership number, I joined several months ago and just received notification of my numbers in an email and they followed up by sending my member card a couple weeks later. Tom's new number is 976 and Merrilee's new number is 976-01. You can access a membership application from our [tn-b.org](http://tn-b.org) web site. Please contact Tom or Stanley if you need any assistance completing your application for the EWMA

# Lets Celebrate



## Birthdays

Betty Roberts 6/8  
Scott Seals 6/13  
Judy Truay 6/16  
Hedie Wiens 6/8  
Liz Pierce 6/10

## Anniversary

Bobbie and Kyle Beeler 6/15  
Mary Jane And Troy Simcox 6/25

# "Chapter Visitation"



Chapter **B** meets the **1st Tuesday** each month at **Shoney's** Clinton Exit 122 off I-75 North  
Eat at 6:00 pm meeting at 7:00 pm.  
Call Tom & Merrilee Peck  
423-494-9818

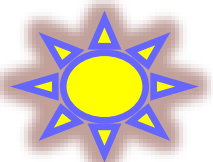

Chapter **A2** meets the **3rd Monday** each month at Shoney's 1021 Lamar Alexander Pkwy Maryville, Eat at 6pm Meeting at 7pm. Chapter Directors Todd & Melanie Freeman 865-963-1051

Chapter **M** meets the **2nd Tuesday** each month.  
Eat at 6:00 pm meeting at 7:00 pm..  
Chapter M meets at Shoney's 1100 Highway 321 Lenoir City, just off I-75 exit 81, CD Brian Richards 865-249-6173

Chapter **F** meets the **3rd Thursday** Golden Corral, 2905 West Andrew Johnson Highway, Morristown, TN 37814. Eat 6:30 pm/Meet 7:30 pm CD Gene & Donna Dunn 631-848-9435

Chapter **C** meets the **3rd Tuesday** each month at Randall's Restaurant Hwy 11W and 120 Old Union Rd, Church Hill TN Eat at 5:30 and the Gathering starts at 6:30. Tom & Carolyn Jarrell 423-383-0339

**LET'S GO SHOPPING!**  
See the "Quarter Master"

Under Construction and looking for a new clerk





Visit our web site and follow the links to join this new and exciting association now that our GWRRRA association closed down its operations.

Forward your membership numbers to Stanley after you receive them from National as we build our member roster moving forward with our membership drawing at each chapter meeting.



# Eagle Wings Motorcycle Association Team Structure

This is intended only as an example as to what we have envisioned how this new Association would look like.

## CEO/ President

### **International Team:**

Vice President of Operations, Vice President of Safety/Ride Coordinator, Vice President of Finance and Vice President of Special Operations

### **Regional Team:**

Regional Director, Regional Safety/Ride Coordinator, Regional Treasurer

### **District Team:**

District Director, District Safety/Ride Coordinator, District Treasurer

### **Chapter Team:**

Chapter Director, Chapter Safety/Ride Coordinator, Chapter Treasurer

The Directors would be appointed by the Director above them and the Director would appoint their own Team with approval of the Team above them, like the Chapter SRC would be appointed by the CD with approval of the DSRC and so on.